

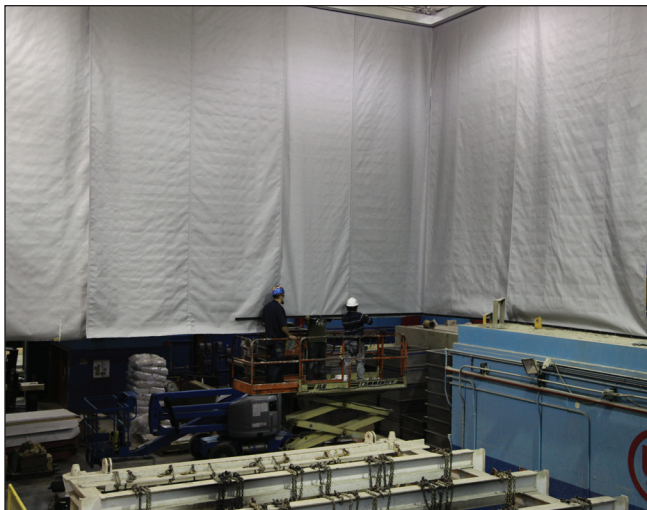

### GENERAL DESCRIPTION:

Electrically operated automatic smoke containment barrier that provides smoke and fire protection for a variety of applications: multilevel atria smoke control, opening protective, smoke barriers.

- Manufactured from 1.2mm galvanized steel, curtain head box rated at same temperature as curtain.
- Removable cover plates are incorporated to allow access to the curtain rollers.
- Standard head box sizes are 150mm x 150mm for single rollers (maximum width 5.5m) and 250mm x 150mm for multiple rollers (over 5.5m wide). Larger head boxes may be required where the curtain drop is in excess of 3m.
- Weighted bottom bar is provided to prevent deflection and ensure correct operation under gravity.
- Rollers are constructed from octagonal tube which will incorporate a 24V D.C. motor and gearbox and a sealed heavy duty ball bearing assembly.
- A motor control circuit (MCC) is housed in a steel enclosure and mounted onto the motor end of the head box.
- Descent speed (S) is controlled by back electromagnetic force for each curtain at  $6 \leq S \leq 24$  in./sec. A suitably weighted bottom bar with polycarbonate extrusion at bottom of the box.
- Fabric curtain is manufactured from X32K woven glass. The woven glass fiber fabric has a nominal weight  $\geq 540\text{g/m}^2$  and is UL listed  $\geq 1$  hr.
- Fail Safe Design with battery back-up standard, NOT Required for Gravity Fail Safe Deployment. File R26410 is Ble.



### STANDARDS:

- NFPA 80 Chapter 20:2007
- NFPA 92B
- UL 10D Listed for Fire Protective Curtains
- UL 864 Labeled & Listed UL 555 Labeled & Listed
- UL 10D Labeled & Listed
- UL 10B Time Temperature Curves
- UL 10C Time Temperature Curves NFPA 105 Compliance
- ANSI/ASTM E119 Standard Tests Methods for Fire Tests of Building Construction and Materials

### PERFORMANCE:

- 1-hour smoke and fire curtain (UL 10D/ANSI/ASTM E119)
- 2000 cycles at normal ambient temperatures in the range (32°F - 112°F) and can withstand hot air and smoke at temperatures at UL 10B and ANSI/ASTME119 Time Temperature curves.
- Fabric area density  $\geq 540 \text{ g/m}^2$  for temperature  $\leq 1000^\circ\text{C}$  for a period of 1 hr.
- The tensile strength of Panama weave fabric is  $10\% \geq$ , with  $415\text{g/m}^2$  glass cloth with a  $20\text{g/m}^2$  micronized aluminum polymer coating on each side of the fabric.

### LEED CERTIFICATION

#### CORE & SHELL

- Indoor Environmental Quality
  - Credit 2: Increased Ventilation
  - Credit 4.2: Low Emitting Material
  - Credit 5: Indoor Chemical & Pollutant Control
  - Credit 8: Daylight and Views
- Innovation & Design Process
  - Credit 1.1: Innovation in Design

**SIZES:**

CURTAIN DROP	SINGLE BOX	DOUBLE BOX SIDE BY SIDE	DOUBLE BOX OVER/UNDER
Down to 3'3"	5-1/8" x 4-3/4"	7-7/8" x 5-1/8"	5-7/8" x 9"
Down to 9'10"	57 1/8" x 5-7/8"	10" x 5-7/8"	5-7/8" x 10"

**LOADS:**

- Structural Load: 10-15 lbs./ft.
- Structural Load- Unistrut mount 3/8 threaded rods 4'0" on center- slab mount or to C channel framing
- Electrical Load- 15 amp circuit breaker to one group control panel

FABRIC			
Style: X32K		Rating for 1000° C for 60 minutes	
Test Characteristics	Unit	Data as per examination	Testing method/remark
Weight of the raw fab	g/m <sup>2</sup>	420 ± 5%	DIN 53854
total weight	g/m <sup>2</sup>	420 ± 5%	DIN 53854
Width	Mm	1000 ± 1%	DIN 53854
Thickness	Mm	0.43 ± 5%	DIN 53855 T1
Weave		Panama	
Threads /warp	Per cm	18.0 ± 3%	EN 1049
Fineness /warp	Tex	EC9 - 68x2 ± 5%	DIN 53830
Tensile strength /weft	N/cm	900	DIN 53857 T1
Coating			
Quantity	G/m <sup>2</sup>	35 ± 5%	DIN 52273
One side / both sides	1/2	2	
Application temperature	°C	500 (Glass)	Oven-test

MOTOR CONTROL CIRCUIT SPECIFICATION (MCC)	
Nominal Voltage	24V
Nominal Speed	3100 rpm
Dimensions	145mm H x 250 mm L x 50mm D
Continuous Torque	1400 Ncm
Efficiency	0.70
Ratio	100.00
Shaft Load Capacity- Axial	150N
Shaft Load Capacity- Radial	250
A dynamic braking system housed in the motor control circuit controls the speed of descent of the curtain	

GROUP CONTROL PANEL SPECIFICATION	
Nominal Voltage	24V
Power Supply	230V 50 Hz AC or 120-130V 60Hz AC
Battery	3 Hours, 2 x 7 aph Rechargeable Sealed Lead Acid Cells
Fire Signal	Open on fire - configured fail safe
Test Facility	Key Switch
Indication	Green LED = Mains Healthy Yellow LED = Battery Fault Red LED = Fuse Blown Green LED = Fire Alarm Status Normal
Panel Size	396mm H x 334mm W x 105mm D

## SMOKE CURTAIN DIAGRAM

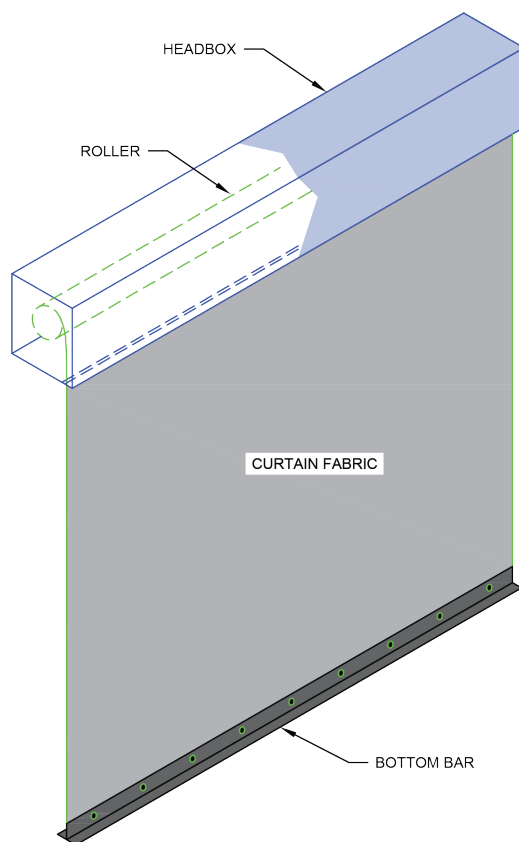

**U.S. SMOKE & FIRE**  
PROTECTING THE PEOPLE®

12310 Pinecrest Road, Suite 300, Reston, VA 20191 • Phone: 888.917.8777 • Fax: 888.917.8777  
Washington, DC • Boston • New York • Miami • Dallas • San Francisco  
[www.usmokeandfire.com](http://www.usmokeandfire.com) • [aeteam@usmokeandfire.com](mailto:aeteam@usmokeandfire.com)



International  
Organization for  
Standardization



UL LOGO IS A REGISTERED TRADEMARK OF UNDERWRITERS LABORATORIES